

# PRESSURE TRANSMITTER

Swiss based Trafag is a leading international supplier of high quality sensors and monitoring instruments for measurement of pressure and temperature. The pressure transmitter NAH 8254 with increased accuracy of 0.3% and optional switching outputs has an exceptionally long-term stable thin-film-on-steel sensor cell with triple (optionally 5-fold) overpressure protection. The robust design and the wide temperature range of -40°C to +125°C make the NAH 8254 the ideal solution when pressure needs to be measured accurately and reliably under rough environmental conditions.



## Applications

- Machine tools
- Hydraulics
- Process technology
- Measuring and test bench technology

## Features

- Measuring accuracy 0.3 %
- Completely welded steel sensor system without additional seals
- Excellent long-term stability
- Optional: 5-fold overpressure resistance
- Optional: Switching output 1 or 2 PNP

Technical Data			
Measuring principle	Thin-film-on-steel	Accuracy @ 25°C typ.	± 0.3 % FS typ.
Measuring range	0 ... 0.2 to 0 ... 700 bar 0 ... 3 to 0 ... 10000 psi	Media temperature	-40°C ... +125°C
Output signal	4 ... 20 mA, 0 ... 5 VDC, 1 ... 5 VDC, 1 ... 6 VDC, 0 ... 10 VDC and more, 0.5 ... 4.5 VDC ratiometric, Switching output: 1 or 2 PNP	Ambient temperature	max. -40°C ... + 125°C (UL-rated Umgebungstemperatur: -20°C ... +80°C) details see section Electrical Connection
NLH @ 25°C (BSL) typ.	± 0.2 % FS typ.		

08/2024

Data sheet H72304z

Subject to change

## Ordering information/type code

Measuring range <sup>1)</sup>	Pressure measurement range [bar]	Over pressure [bar]	Burst pressure [bar]		8254 . XX			XX	XX	XX	XX	XX	
					Pressure measurement range [psi]	Over pressure [psi]	Burst pressure [psi]						
	0 ... 0.2 <sup>10)</sup>	1.2	25	<b>68</b>	0 ... 3 <sup>10)</sup>	15	350	<b>F8</b>					
	0 ... 0.4 <sup>10)</sup>	1.2	25	<b>69</b>	0 ... 5 <sup>10)</sup>	15	350	<b>F9</b>					
	0 ... 0.6 <sup>10)</sup>	1.2	25	<b>70</b>	0 ... 10 <sup>10)</sup>	20	350	<b>G0</b>					
	0 ... 1.0 <sup>10)</sup>	2	25	<b>71</b>	0 ... 15 <sup>10)</sup>	30	350	<b>G1</b>					
	0 ... 1.6 <sup>10)</sup>	3.2	50	<b>73</b>	0 ... 25 <sup>10)</sup>	50	700	<b>G3</b>					
	0 ... 2.5	7.5	50	<b>75</b>	0 ... 30	90	700	<b>G5</b>					
	0 ... 4	12	60	<b>76</b>	0 ... 50	150	850	<b>G6</b>					
	0 ... 6	18	100	<b>77</b>	0 ... 100	300	1450	<b>G7</b>					
	0 ... 10	30	200	<b>78</b>	0 ... 150	450	2500	<b>G8</b>					
	0 ... 16	48	200	<b>79</b>	0 ... 200	600	2500	<b>GA</b>					
	0 ... 25	75	300	<b>80</b>	0 ... 250	750	2500	<b>G9</b>					
	0 ... 40	120	300	<b>81</b>	0 ... 300	900	4000	<b>HA</b>					
	0 ... 60	180	400	<b>82</b>	0 ... 400	1200	4000	<b>H0</b>					
	0 ... 100	300	500	<b>83</b>	0 ... 500	1500	4000	<b>H1</b>					
	0 ... 160	480	750	<b>85</b>	0 ... 1000	3000	5000	<b>H2</b>					
	0 ... 250	750	1000	<b>74</b>	0 ... 1500	4500	7000	<b>H3</b>					
	0 ... 400	1000	2000	<b>84</b>	0 ... 2000	6000	10000	<b>H5</b>					
	0 ... 600	1500	2500	<b>86</b>	0 ... 3000	9000	14500	<b>G4</b>					
	0 ... 700	1500	2500	<b>87</b>	0 ... 5000	12500	21750	<b>H4</b>					
					0 ... 7500	18750	29000	<b>H6</b>					
					0 ... 10000	18750	29000	<b>H7</b>					
	<b>Option 5P:</b>	<b>Fivefold overpressure</b>			<b>Option:</b>	<b>Maximum Overpressure</b>							
	0 ... 2.5	12.5	60	<b>55</b>	0 ... 30	150	1450	<b>E5</b>					
	0 ... 4	20	100	<b>56</b>	0 ... 50	180	1450	<b>E6</b>					
	0 ... 6	30	200	<b>57</b>	0 ... 100	450	3500	<b>E7</b>					
	0 ... 10	50	200	<b>58</b>	0 ... 150	700	4250	<b>E8</b>					
	0 ... 16	80	300	<b>59</b>	0 ... 200	700	4250	<b>EA</b>					
	0 ... 25	125	300	<b>60</b>	0 ... 250	1150	5750	<b>E9</b>					
	0 ... 40	200	400	<b>61</b>	0 ... 300	1150	5750	<b>FA</b>					
	0 ... 60	300	500	<b>62</b>	0 ... 400	1800	8500	<b>F0</b>					
	0 ... 100	500	750	<b>63</b>	0 ... 500	1800	8500	<b>F1</b>					
	0 ... 160	800	1000	<b>65</b>	0 ... 1000	4600	19000	<b>F2</b>					

**Sensor** Relative pressure, accuracy: 0.3 % 23

<b>Pressure connection</b>	G1/4" male, seal: DIN 3869 (accessory 61/63/83)	<b>17</b>	9/16"-18UNF-2A male, SAE J1926-2 (Heavy Duty), seal: accessory 61 <sup>15)</sup>	<b>67</b>
	G1/4" male, with integrated damping Ø 0.5 mm, Seal: DIN 3869 (accessories 61/63/83) <sup>16)</sup>	<b>15</b>	R1/4" male, DIN3858	<b>19</b>
	G1/4" male (Manometer) EN 837	<b>53</b>	R1/4" male, DIN2999 <sup>9)</sup>	<b>20</b>
	G1/8" male DIN3852-E, seal: accessory 61 <sup>5)</sup>	<b>54</b>	R1/8" male, DIN3858 <sup>5)</sup>	<b>16</b>
	1/4" NPT male	<b>30</b>	M10x1 male, DIN EN ISO 6149-2, seal: accessory 61	<b>32</b>
	1/8" NPT male <sup>13)</sup>	<b>43</b>	M12x1 male, seal: accessory 61 <sup>12)</sup>	<b>64</b>
	7/16"-20UNF female, SAE J512 with valve opener <sup>4)</sup>	<b>24</b>	M12x1.25 male, seal: accessory 61 <sup>12)</sup>	<b>65</b>
	7/16"-20UNF female, SAE J512 without valve opener <sup>4)</sup>	<b>44</b>	M12x1.5 male, DIN EN ISO 9974-2, seal: accessory 61	<b>49</b>
	7/16"-20UNF male, DIN3866 <sup>4)</sup>	<b>18</b>	M14x1.5 male DIN EN ISO 6149-2, seal: accessory 61 <sup>9)</sup>	<b>31</b>
	7/16"-20UNF-2A male, SAE J1926-2 (Heavy Duty), seal: accessory 61/63 <sup>15)</sup>	<b>69</b>		

<b>Electrical connection</b>	Male electrical connector, industrial standard, contact distance 9.4 mm, Mat. PA, EN 175301-803C	01
	Male electrical connector M12x1, 4-pole, Mat. PA, IEC 61076-2-101	32
	Male electrical connector M12x1, 5-pole, Mat. PA, IEC 61076-2-101	35
	Male electrical connector MIL-C 26482, 6-pole, metal	02
	Male electrical connector Deutsch DT04-3P, 3-pole	D3
	Male electrical connector Deutsch DT04-4P, 4-pole	D4
	Cable Mat. PVC, IP67/IP68, 2 x 2 x 0.14 mm <sup>2</sup> , max. traction on cable: 2 N <sup>7)</sup>	22
	Cable Mat. PUR, IP67/IP68, 4 x 0.25 mm <sup>2</sup> , shielded <sup>7)</sup>	24
	Cable Mat. EPD Raychem FDR25, IP67, 4 x 0.2 mm <sup>2</sup> , shielded <sup>7)</sup>	08
	Cable Mat. Radox Tenuis, IP67/IP68, 4 x 0.5 mm <sup>2</sup> , shielded <sup>7)</sup>	88
	Compact design: Cable Mat. PVC, IP40, 2 x 2 x 0.14 mm <sup>2</sup> , shielded, max. traction on cable: 2 N <sup>9) 17) 18)</sup>	A1
	JST (or compatible) Board to Cable/Wire Disconnectable Crimp style connector, BM04B-SRSS-TB, IP20, 4-pole <sup>9) 18)</sup>	J4

<b>Output signal</b>	Signal output	Load resistance	I (supply)	U (supply)	
	4 ... 20 mA	See graphic		(= signal output)	24 (9 ... 32) VDC
0.5 ... 4.5 VDC <sup>4)</sup>	≥ 5.0 kΩ to Us-		≤ 20 mA	24 (9 ... 32) VDC	20
0 ... 5 VDC	≥ 5.0 kΩ to Us-		≤ 20 mA	24 (9 ... 32) VDC	14
0.1 ... 4.1 VDC	≥ 5.0 kΩ to Us-		≤ 20 mA	24 (9 ... 32) VDC	28
0.1 ... 5.1 VDC	≥ 5.0 kΩ to Us-		≤ 20 mA	24 (9 ... 32) VDC	29
0.5 ... 5 VDC	≥ 5.0 kΩ to Us-		≤ 20 mA	24 (9 ... 32) VDC	22
1 ... 5 VDC <sup>6)</sup>	≥ 5.0 kΩ to Us-		≤ 20 mA	24 (9 ... 32) VDC	25
0.5 ... 5.5 VDC	≥ 5.0 kΩ to Us-		≤ 20 mA	24 (9 ... 32) VDC	24
1 ... 6 VDC	≥ 5.0 kΩ to Us-		≤ 20 mA	24 (9 ... 32) VDC	16
0 ... 10 VDC	≥ 5.0 kΩ to Us-		≤ 15 mA	24 (15 ... 32) VDC	17
1 ... 10 VDC	≥ 5.0 kΩ to Us-		≤ 15 mA	24 (15 ... 32) VDC	26
0.1 ... 10.1 VDC	≥ 5.0 kΩ to Us-		≤ 15 mA	24 (15 ... 32) VDC	13
0.5 ... 4.5 VDC ratiom.	≥ 5.0 kΩ to Us-		≤ 10 mA	5 (4.75 ... 5.25) VDC	23
2 PNP transistors <sup>3)</sup>			≤ 10 mA	24 (9 ... 32) VDC	PS
1 PNP transistor <sup>11)</sup>			≤ 10 mA	24 (9 ... 32) VDC	T1

<b>Accessories</b>	Female electrical plug M12x1, 5-pole <sup>2)</sup>	33
	Female electrical plug industrial standard (for electrical connection 01), EN 175301-803C	34
	Pressure peak damping element ø 1.0 mm <sup>4)</sup>	40
	Pressure peak damping element ø 0.4 mm <sup>4)</sup>	44
	Seal FKM, -18°C ... +125°C	61
	Seal EPDM, -40°C ... +125°C	63
	Seal NBR, -25°C ... +100°C	83
	Special electrical connection: Pin 2 +, Pin 3 Ground, Pin 4 - (only for output signal 19 and male electrical connector 01, industrial standard)	90
	Special electrical connection: Pin 1 Out, Pin 2 +, Pin 3 Ground, Pin 4 - (only for output signals 13, 14, 16, 17, 20, 22, 23, 24, 25, 26, 28, 29 and male electrical connector 01, industrial standard)	91
	Special electrical connection: Pin 1 +, Pin 2 Ground, Pin 3 Out, Pin 4 - (only for output signals 13, 14, 16, 17, 20, 22, 23, 24, 25, 26, 28, 29 and male electrical connector 32, M12x1, 4-pole)	95
	Special electrical connection: Pin 1 +, Pin 2 Ground, Pin 3 -, Pin 4 Out (only for output signals 13, 14, 16, 17, 20, 22, 23, 24, 25, 26, 28, 29 and male electrical connector 32, M12x1, 4-pole)	96
	Special electrical connection: Pin 1 +, Pin 3 -, Pin 4 Out (only for output signals 13, 14, 16, 17, 20, 22, 23, 24, 25, 26, 28, 29 and male electrical connector 32, M12x1, 4-pole)	G1
	Special electrical connection: Pin 1 +, Pin 2 -, Pin 4 Ground (only for output signal 19 and male electrical connector 01, industrial standard)	92
	Special electrical connection: Pin 1 +, Pin 2 -, Pin 4 Ground (only for output signal 19 and male electrical connector 32, M12x1, 4-pole)	E1
	Special electrical connection: Pin 1 +, Pin 2 -, Pin 3 Out, Pin 4 Ground (only for output signals 13, 14, 16, 17, 20, 22, 23, 24, 25, 26, 28, 29 and male electrical connector 32, M12x1, 4-pole)	E2
	Special electrical connection: Pin 1 Out, Pin 2 -, Pin 3 +, Pin 4 Ground (only for output signals 13, 14, 16, 17, 20, 22, 23, 24, 25, 26, 28, 29 and male electrical connector 01, industrial standard)	E3
	Special electrical connection: Pin 1 +, Pin 2 -, Pin 3 Out, Pin 4 Ground (only for output signals 13, 14, 16, 17, 20, 22, 23, 24, 25, 26, 28, 29 and male electrical connector 01, industrial standard)	E9
	Special electrical connection: Pin 1 +, Pin 2 Ground, Pin 4 - (only for output signal 19 and male electrical connector 32, M12x1, 4-pole)	E6
	Special electrical connection: Pin A +, Pin C - (only for output signal 19 and male electrical connector Deutsch DT04-3P, 3-pole)	F0
	Special electrical connection: Pin A +, Pin B Out, Pin C - (only for output signals 13, 14, 16, 17, 20, 22, 23, 24, 25, 26, 28, 29 and male electrical connector Deutsch DT04-3P, 3-pole)	F1
	Special electrical connection: Pin 2 +, Pin 3 - (only for output signals 19 and male electrical connector Deutsch DT04-4P, 4-pole)	G3
	Special electrical connection: Pin 1 Out, Pin 2 +, Pin 3 - (only for output signals 13, 14, 16, 17, 20, 22, 23, 24, 25, 26, 28, 29 and male electrical connector Deutsch DT04-4P, 4-pole)	G4
	Special electrical connection: Pin A +, Pin C Out, Pin B/D -, Pin E Ground (Pin B and D are connected) (only for output signals 13, 14, 16, 17, 20, 22, 23, 24, 25, 26, 28, 29 and male electrical connector 02, MIL-C 26482)	F3
	Special electrical connection: Pin 1 +, Pin 2 - (only for output signal 19 and male electrical connector 32, M12x1, 4-pole)	F4
	Special electrical connection: Pin 1 +, Pin 3 - (only for output signal 19 and male electrical connector 32, M12x1, 4-pole)	F5
	Special electrical connection: Pin 1 +, Pin 2 -, Pin 3 -, Pin 4 Ground (only for output signals 19 and male electrical connector 32, M12x1, 4-pole)	G2
	Special electrical connection: Pin 1 +, Pin 4 - (only for output signals 19 and male electrical connector 32, M12x1, 4-pole)	G5
	Special electrical connection: Pin 2 -, Pin 3 +, Pin 4 Ground (only for output signals 19 and male electrical connector 32, M12x1, 4-pole)	G8
	Special electrical connection: Pin 1 +, Pin 2 Out, Pin 3 Ground, Pin 4 - (only for output signals 13, 14, 16, 17, 20, 22, 23, 24, 25, 26, 28, 29 and male electrical connector 32, M12x1, 4-pole)	F6
	Special electrical connection: Pin 1 +, Pin 2 Out, Pin 3 - (only for output signals 13, 14, 16, 17, 20, 22, 23, 24, 25, 26, 28, 29 and male electrical connector 32, M12x1, 4-pole)	F7
	Cable length 0.5 m	EM
	Cable length 1.0 m	1M
	Cable length 2.0 m	2M
	Parametrisation according to customer specification for output signal PS, T1 (see table "Parameters")	ZC
	Parametrisation standard for output signal PS, T1 (see table "Parameters")	ZS
	Multiple packaging <sup>8)</sup>	VM
	Signal processing, cut-off frequency (see table Signal processing)	
	UL-listed version <sup>14)</sup>	UL

<sup>1)</sup> Customized pressure ranges upon request

<sup>2)</sup> For electrical connections 32 and 35

<sup>3)</sup> Only with electrical connections 32, 22, 24, 08, 88

<sup>4)</sup> Max. allowable pressure range 60 bar (870 psi) at 180 bar (2610 psi) overpressure

<sup>5)</sup> Max. allowable pressure range 160 bar (2320 psi) at 480 bar (6961 psi) overpressure

<sup>6)</sup> Not for pressure connections 53, 24, 44, 18

<sup>7)</sup> Cable length see accessories

<sup>8)</sup> The order quantity must be a multiple of 50, only for electrical connections 01, 32, 35, 02, D3, D4, not for pressure connection 30 with electrical connections 02, D3, D4

<sup>9)</sup> Upon request

<sup>10)</sup> Only for pressure connections 15, 17 and 30 and with output signal 4 ... 20 mA, code 19

<sup>11)</sup> Only with electrical connections 32, 22, 24, 08, 88, D3

<sup>12)</sup> Without seal, use seal geometry according DIN EN ISO 6149-2

<sup>13)</sup> Max. allowable pressure range 400 bar (5800 psi) at 600 bar (8700 psi) overpressure

<sup>14)</sup> Possible type code combinations for UL-listed versions see separate table

<sup>15)</sup> Measuring range max. 630 bar according to SAE J1926-2 (Heavy Duty)

<sup>16)</sup> For measuring ranges  $\geq 2.5$  bar

<sup>17)</sup> Cable length 2m only, with accessory 2M

<sup>18)</sup> Not UL-listed

## Signal processing

Code	Cut-off frequency $f_G$	Rise time (10 ... 90 % nominal pressure)	Output signal			
			4 ... 20 mA	0.5 ... 4.5 VDC ratiometric	0 ... 6 VDC	0 ... 10 VDC
GA <sup>1)</sup>	11 Hz	32 ms	x	x	-	-
GS <sup>1) 2)</sup>	14 kHz	29 $\mu$ s	x	-	-	-
GU <sup>1) 2)</sup>	20 kHz	18 $\mu$ s	-	x	-	-
Standard specification	350 Hz	1 ms	x	x	x	x

<sup>1)</sup> Upon request

<sup>2)</sup> Only with electrical connections 32, 35 with shielded cable and 22, 24, 08, 88, only for pressure ranges  $\geq 2$  bar

## Standard products (extra short lead time)

Product No.	Type Code	Pressure range [bar]	Over pressure max. [bar]	Supply [VDC]	Accuracy @ 25°C typ. [%]
NAH0.2A	8254 68 2317 32 0000 0000 19 33 44 61	0 ... 0.2	1.2	9 ... 32	$\pm 0.8$
NAH0.4A	8254 69 2317 32 0000 0000 19 33 44 61	0 ... 0.4	1.2	9 ... 32	$\pm 0.8$
NAH0.6A	8254 70 2317 32 0000 0000 19 33 44 61	0 ... 0.6	1.2	9 ... 32	$\pm 0.8$
NAH1.0A	8254 71 2317 32 0000 0000 19 33 44 61	0 ... 1.0	2	9 ... 32	$\pm 0.6$
NAH1.6A	8254 73 2317 32 0000 0000 19 33 44 61	0 ... 1.6	3.2	9 ... 32	$\pm 0.6$
NAH2.5A	8254 75 2317 32 0000 0000 19 33 44 61	0 ... 2.5	7.5	9 ... 32	$\pm 0.3$
NAH4.0A	8254 76 2317 32 0000 0000 19 33 44 61	0 ... 4	12	9 ... 32	$\pm 0.3$
NAH6.0A	8254 77 2317 32 0000 0000 19 33 44 61	0 ... 6	18	9 ... 32	$\pm 0.3$
NAH10.0A	8254 78 2317 32 0000 0000 19 33 44 61	0 ... 10	30	9 ... 32	$\pm 0.3$
NAH16.0A	8254 79 2317 32 0000 0000 19 33 44 61	0 ... 16	48	9 ... 32	$\pm 0.3$
NAH25.0A	8254 80 2317 32 0000 0000 19 33 44 61	0 ... 25	75	9 ... 32	$\pm 0.3$
NAH40.0A	8254 81 2317 32 0000 0000 19 33 44 61	0 ... 40	120	9 ... 32	$\pm 0.3$
NAH100.0A	8254 83 2317 32 0000 0000 19 33 44 61	0 ... 100	300	9 ... 32	$\pm 0.3$
NAH250.0A	8254 74 2317 32 0000 0000 19 33 44 61	0 ... 250	750	9 ... 32	$\pm 0.3$
NAH400.0A	8254 84 2317 32 0000 0000 19 33 44 61	0 ... 400	1000	9 ... 32	$\pm 0.3$
NAH600.0A	8254 86 2317 32 0000 0000 19 33 44 61	0 ... 600	1500	9 ... 32	$\pm 0.3$

## Ordering information: Possible type code combinations for UL-listed versions

	Combination with UL
Measuring range	all ranges $\leq 700$ bar
Sensor	all codes on datasheet
Pressure connection	all codes on datasheet
Electrical connection	all codes except A1 and J4
Output signal	all codes except PS and T1
Accessories	all codes except GA, GS and GU

Parameters				
Name	Standard setting (accessory ZS)	Value range	Short name	Customer adjustment (accessory ZC)
Switch point SP1 (hysteresis mode) Upper switch point FH1 (window mode)	75 % Measuring range	> RP1, FL1 (2 ... 99 %) Hysteresis $\geq$ 1 % FS	SP1	
Reset point RP1 (hysteresis mode) Lower switch point FL1 (window mode)	25 % Measuring range	< SP1, FH1 (1 ... 98 %) Hysteresis $\geq$ 1 % FS	RP1	
Switch point SP2 (hysteresis mode) Upper switch point FH2 (window mode)	75 % Measuring range	> RP2, FL2 (2 ... 99 %) Hysteresis $\geq$ 1 % FS	SP2	
Reset point RP2 (hysteresis mode) Lower switch point FL2 (window mode)	25 % Measuring range	< SP2, FH2 (1 ... 98 %) Hysteresis $\geq$ 1 % FS	RP2	
Switch point delay time SP1 / RP1 (hysteresis mode) Switch point delay time FH1 / FL1 (window mode)	0	0; approx. 2 <sup>x</sup> [ms], x = 3, 4 ... 16	dS1	
Switch point delay time SP2 / RP2 (hysteresis mode) Switch point delay time FH2 / FL2 (window mode)	0	0; approx. 2 <sup>x</sup> [ms], x = 3, 4 ... 16	dS2	
Functions switching output 1	Hysteresis, closer (Hno)	Hysteresis NO (Hno), Hysteresis NC (Hnc) Window NO (Fno), Window NC (Fnc)	ou1	
Functions switching output 2	Hysteresis, closer (Hno)	Hysteresis NO (Hno), Hysteresis NC (Hnc) Window NO (Fno), Window NC (Fnc) Device ready	ou2	

## Parameterization of switching points

The switching points, delay times and output functions can be parameterised quickly and easily with the Sensor Master Communicator (SMC) application, which is available for Windows (PC) and Android smartphone.

The Android app is available in the Google Play Store and the Windows app is available in the Microsoft Store. The apps are free of charge.

- Data sheet SMI Sensor Master Interface: [www.trafag.com/H72618](http://www.trafag.com/H72618)
- Instruction for the Sensor Master Communicator App (SMC) and the Sensor Master Interface (SMI): [www.trafag.com/H73618](http://www.trafag.com/H73618)



Specifications		
<b>Electrical data</b>	Output / supply voltage	4 ... 20 mA: 24 (9...32) VDC 0 ... 6 VDC ranges: 24 (9...32) VDC 0 ... 10.1 VDC ranges: 24 (15...32) 0.5 ... 4.5 VDC ratiom., 10 ... 90% $U_{supply}$ : $5 \pm 0.25$ VDC 1 or 2 PNP transistors: 24 (9...32) VDC
	Rise time	Rise time of the supply voltage: > 32 V/s
	Power-on delay time pressure transmitters	100 ms
	Power-on delay time pressure switches	50 ms + switching delay time
	Inverse-polarity protection, short-circuit strength @ 25°C during 5 min.	4...20 mA: to $U_s = 32$ VDC 0 ... 6 VDC ranges, 0 ... 10.1 VDC ranges: bis $U_s = 28$ VDC 0.5...4.5 VDC ratiometric: to $U_s = 14$ VDC 1 or 2 PNP transistors: to $U_s = 32$ VDC
<b>Environmental conditions</b>	Media temperature	-40°C ... +125°C
	Ambient temperature	max. -40°C ... + 125°C (UL-rated Umgebungstemperatur: -20°C ... +80°C) details see section Electrical Connection
	Protection	IP20, IP40, IP65, IP67, IP68 details see section Electrical Connection
	Humidity	Max. 95 % relative
	Vibration	15 g RMS (20...2000 Hz) (EN60068-2-64) 25 g sin (80...2000 Hz), 1 oct./min, (1x @ 25°C) (EN60068-2-6)
	Shock	50 g / 11 ms 100 g / 6 ms Male electrical plug M12x1 (EN60068-2-27) <sup>2)</sup>
<b>EMC protection</b> <sup>1)</sup>	Emission	EN/IEC 61000-6-3
	Immunity	EN/IEC 61000-6-2
<b>Mechanical data</b>	Sensor (wetted parts)	1.4542 (AISI630)
	Pressure connection (wetted parts)	1.4542 (AISI630)
	Housing	1.4301 (AISI304)
	Sealing	FKM/EPDM/NBR
	Male electrical connector	See ordering information
	Weight	appr. 50 g
	Mounting torque	25 Nm

<sup>1)</sup> Electrical connection J4 not EMC tested

<sup>2)</sup> For electrical connections 32 and 35

## Analogue output

			$\geq 0.2 \text{ bar}$ $\leq 0.6 \text{ bar}$	$> 0.6 \text{ bar}$ $< 2.0 \text{ bar}$	$\geq 2.0 \text{ bar}$
Accuracy	TEB @ -25 ... +85°C	[% FS typ.]	$\pm 2.0$	$\pm 1.5$	$\pm 1.0$
	Accuracy @ +25°C	[% FS typ.]	$\pm 0.8$	$\pm 0.6$	$\pm 0.3$
	NLH @ +25°C (BSL)	[% FS typ.]	$\pm 0.2$	$\pm 0.2$	$\pm 0.2$
	TC zero point and span	[% FS/K typ.]	$\pm 0.02$	$\pm 0.02$	$\pm 0.01$
	Long term stability 1 year @ +25°C	[% FS typ.]	$\pm 0.3$	$\pm 0.2$	$\pm 0.1$
Rise time	Typ. 1 ms / 10 ... 90 % nominal pressure		0.5 mbar	0.5 mbar	0.5 mbar

## Switching output

Accuracy	TEB @ -25 ... +85°C	[% FS typ.]	$\pm 1.0$
	Accuracy @ +25°C	[% FS typ.]	$\pm 0.3$
	Long term stability 1 year @ +25°C	[% FS typ.]	$\pm 0.1$
Setting range of switchpoints	1 ... 99 % FS		
Distance switch point	$\geq 1.0$ % FS		
Switch point > reset point	Switchpoint > reset point		
Switching resistance	$\leq 3 \Omega$		
Output function	Hysteresis, Window; normally closed (NO), normally open (NC)		
Switching current	-40°C ... +85°C	(Ambient and media temperature)	$\leq 400 \text{ mA}$ , total of both switching outputs
	+85°C ... +125°C	(Ambient and media temperature)	$\leq 200 \text{ mA}$ , total of both switching outputs
Current limiting	integrated		
Lifetime	$> 100 \times 10^6$ cycles		
Delay time	0; approx. $2^x$ [ms], $x = 3, 4 \dots 16$		
Switching frequency	max. 60 Hz (at switching delay time = 0)		

## Measuring accuracy

$\geq 0.2 \text{ bar} \dots \leq 0.6 \text{ bar}$

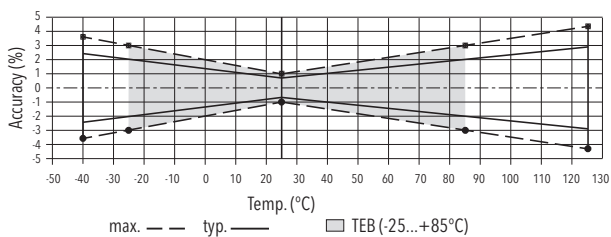

$> 0.6 \text{ bar} \dots < 2.0 \text{ bar}$

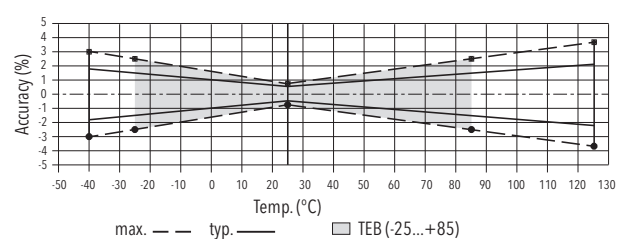

$\geq 2.0 \text{ bar}$

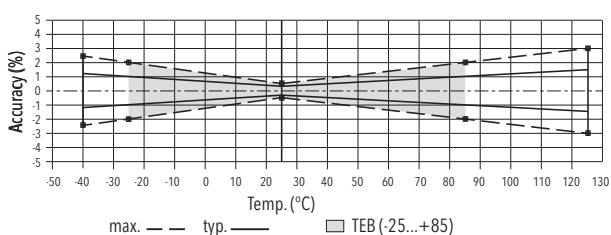



## Dimensions

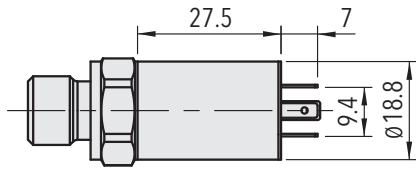

8254.XX.XXXX.01.XX.XX

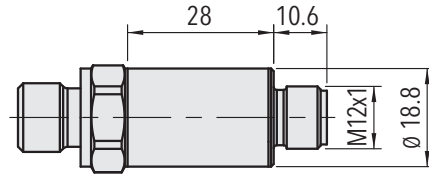

8254.XX.XXXX.32/35.XX.XX

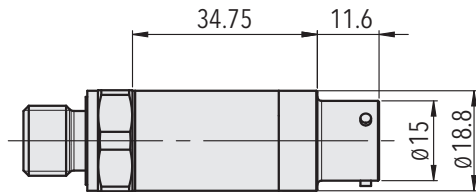

8254.XX.XXXX.02.XX.XX

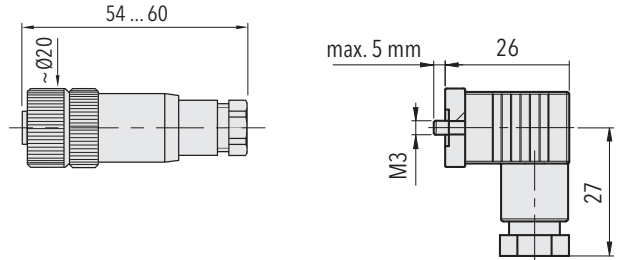

8254.XX.XXXX.XX.XX.33

8254.XX.XXXX.XX.XX.34

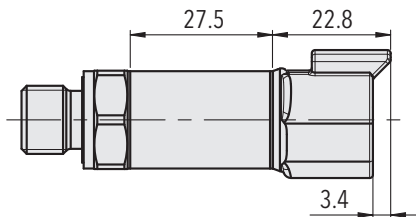

8254.XX.XXXX.D3.XX.XX

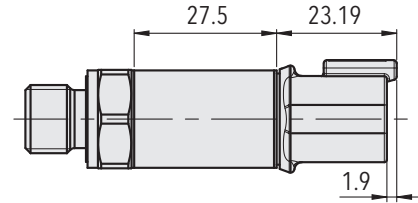

8254.XX.XXXX.D4.XX.XX

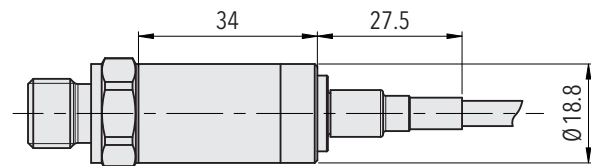

8254.XX.XXXX.08.XX.XX

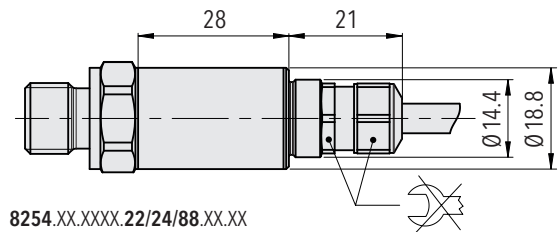

8254.XX.XXXX.22/24/88.XX.XX

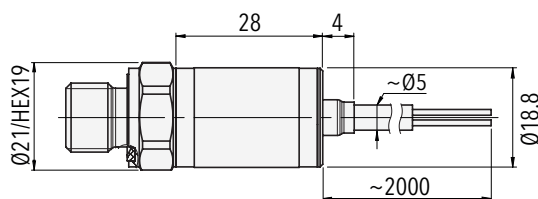

8254.XX.XXXX.A1.XX.XX

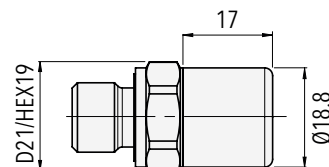

8254.XX.XXXX.J4.XX.XX

## Dimensions

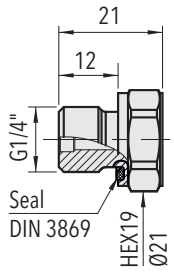

8254.XX.XX17.XX.XX.XX

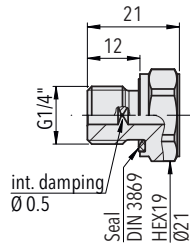

8254.XX.XX15.XX.XX.XX

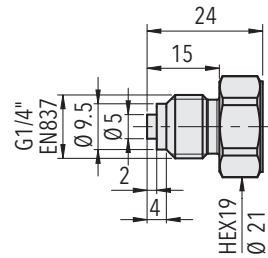

8254.XX.XX53.XX.XX.XX

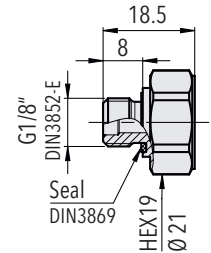

8254.XX.XX54.XX.XX.XX

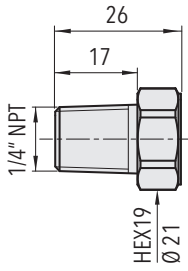

8254.XX.XX30.XX.XX.XX

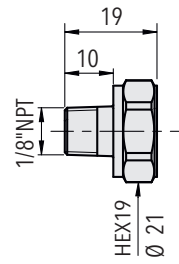

8254.XX.XX43.XX.XX.XX

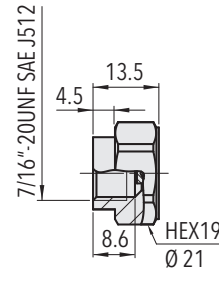

8254.XX.XX24.XX.XX.XX

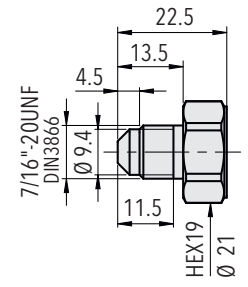

8254.XX.XX18.XX.XX.XX

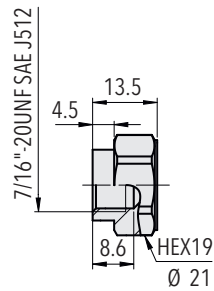

8254.XX.XX44.XX.XX.XX

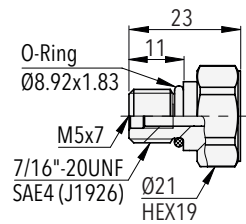

8254.XX.XX69.XX.XX.XX

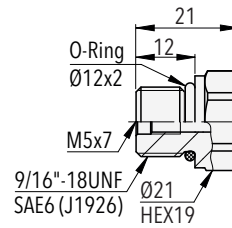

8254.XX.XX67.XX.XX.XX

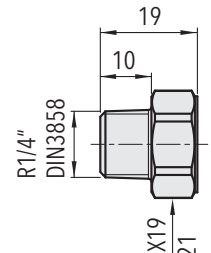

8254.XX.XX19.XX.XX.XX

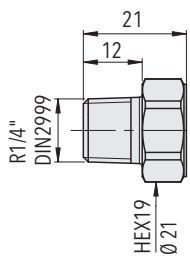

8254.XX.XX20.XX.XX.XX

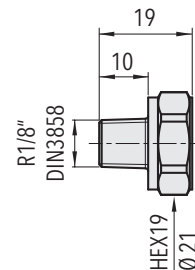

8254.XX.XX16.XX.XX.XX

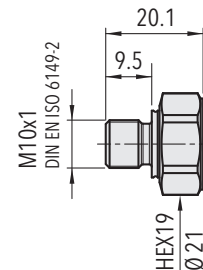

8254.XX.XX32.XX.XX.XX

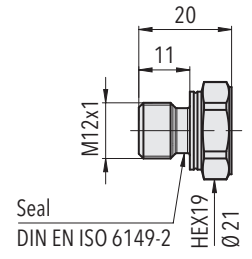

8254.XX.XX64.XX.XX.XX

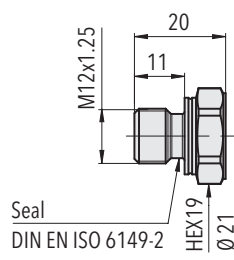

8254.XX.XX65.XX.XX.XX

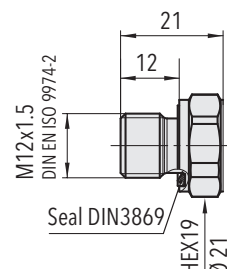

8254.XX.XX49.XX.XX.XX

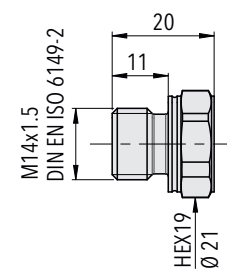

8254.XX.XX31.XX.XX.XX

## Electrical connection

		Protection / electrical connection																
		IP65 <sup>1) 2)</sup>			IP67 <sup>1) 2)</sup>					IP67 <sup>1) 2)</sup>		IP67, IP68 <sup>1) 3)</sup>		IP67, IP68 <sup>1) 3)</sup>				
		Industrial standard Contact distance 9.4 mm			M12x1 4-pole					5-pole		MIL-C 26482		DT04-3P 3-pole		DT04-4P 4-pole		
		<b>01</b>			<b>32</b>					<b>35</b>		<b>02</b>		<b>D3</b>		<b>D4</b>		
Ambient temperature		-40°C ... +80°C			-40°C ... +125°C							-40°C ... +125°C						
UL-rated ambient temperature		-20°C ... +80°C			-20°C ... +80°C							-20°C ... +80°C						
Output signal	<p><b>8254.xx.xxxx.xx.19</b></p>	<b>90</b>	<b>92</b>	<b>E1</b>	<b>E6</b>	<b>F4</b>	<b>F5</b>	<b>G2</b>	<b>G5</b>	<b>G8</b>				<b>F0</b>		<b>G3</b>		
	<p><b>8254.xx.xxxx.xx.13/14/16/17/20/22/ 23/24/25/26/28/29</b></p>	<b>91</b>	<b>E3</b>	<b>E9</b>	<b>95</b>	<b>96</b>	<b>E2</b>	<b>F6</b>	<b>F7</b>	<b>G1</b>			<b>F3</b>	<b>F1</b>		<b>G4</b>		
		2	2	1	1	1	1	1	1	1	3	4	A	A	A	2	2	
		1	4	2	3	2	4	2	3	2/3	4	2	1	B	B	C	1	3
		4	3	4	4	4	2			4	4	5	E			3		
		1	2	3	1	1	1	1	1	1	1	2	A	A	A	A	2	2
		2	1	1	3	2	3	4	3	2	2	4	B	C	C	B	4	1
		3	4	2	2	3	4	3	2	4	3	3	C/D	B/D	B	C	1	3
		4	3	4	4	4	2	2	4	3		5	E	E		3		



<sup>1)</sup> Provided female electrical plug is mounted according to instructions

<sup>2)</sup> Ventilation via male electric plug/cable end

<sup>3)</sup> IP68, 100 mbar, 4h

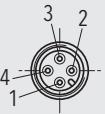
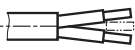
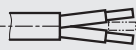
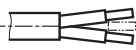
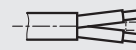
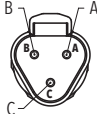
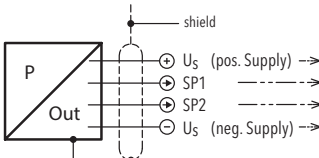
## Electrical connection

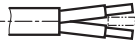
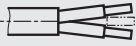
		Protection / electrical connection									
		IP67 <sup>1) 2)</sup>	IP67, IP68 <sup>2) 3)</sup>	IP67, IP68 <sup>2) 3)</sup>	IP67 <sup>2)</sup>	IP67, IP68 <sup>2) 3)</sup>	IP67, IP68 <sup>1) 4)</sup>				
		M12x1 4-pole <b>32</b> 	Cable <b>22</b> 	Cable <b>24</b> 	Cable <b>08</b> 	Cable <b>88</b> 	DT04-3P 3-pole <b>D3</b> 				
Ambient temperature		-40°C ... +125°C	-5°C ... +60°C	-40°C ... +70°C	-40°C ... +125°C	-40°C ... +100°C	-40°C ... +125°C				
UL-rated ambient temperature		-20°C ... +80°C	-5°C ... +60°C	-20°C ... +70°C	-20°C ... +80°C	-20°C ... +80°C	-20°C ... +80°C				
Output signal		<b>PS</b>	<b>T1</b>	<b>PS</b>	<b>T1</b>	<b>PS</b>	<b>T1</b>	<b>PS</b>	<b>T1</b>	<b>T1</b>	
	<b>8254.xx.xxxx.xx.PS/T1</b>	1 4 2 3	1 4 - 3	white green yellow brown	white green - brown	white green yellow brown	white green - brown	red white green black	red white - black	brown blue yellow / green black	brown blue - black

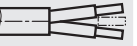
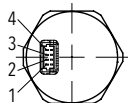
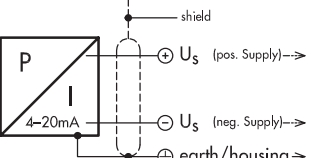
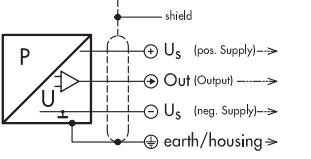
		Protection / electrical connection						
		IP67, IP68 <sup>2) 3)</sup>	IP67, IP68 <sup>2) 3)</sup>	IP67 <sup>2)</sup>	IP67, IP68 <sup>2) 3)</sup>	IP40	IP20	
		Cable <b>22</b> 	Cable <b>24</b> 	Cable <b>08</b> 	Cable <b>88</b> 	Cable <b>A1</b> 	JST SH Series <b>J4</b> 	
Ambient temperature		-5°C ... +60°C	-40°C ... +70°C	-40°C ... +125°C	-40°C ... +100°C	-5°C ... +60°C	-40°C ... +85°C	
UL-rated ambient temperature		-5°C ... +60°C	-20°C ... +70°C	-20°C ... +80°C	-20°C ... +80°C	Not UL-listed	Not UL-listed	
Output signal		<b>8254.xx.xxxx.xx.19</b>	white brown yellow	white brown yellow	red black green	brown black yellow / green	white brown yellow	white brown yellow
		<b>8254.xx.xxxx.xx.13/14/16/17/20/22/ 23/24/25/26/28/29</b>	white green brown yellow	white green brown yellow	red white black green	brown blue black yellow / green	white green brown yellow	white green brown yellow

<sup>1)</sup> Provided female electrical plug is mounted according to instructions

<sup>2)</sup> Ventilation via male electric plug/cable end

<sup>3)</sup> IP68, 20 bar, 30 min.

<sup>4)</sup> IP68, 100 mbar, 4h

4...20mA: min./max resistor vs. supply voltage @ Pmax = 100%

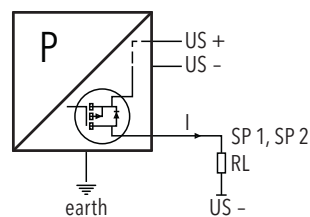
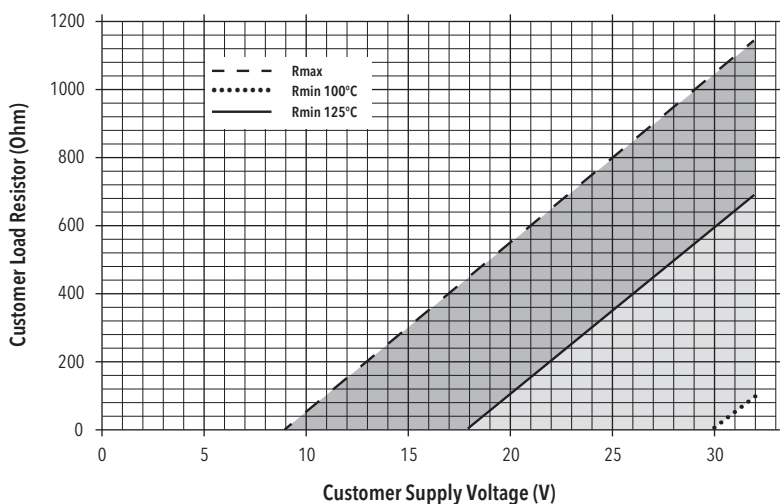

Connection of loads to switching output

## Functions switching output

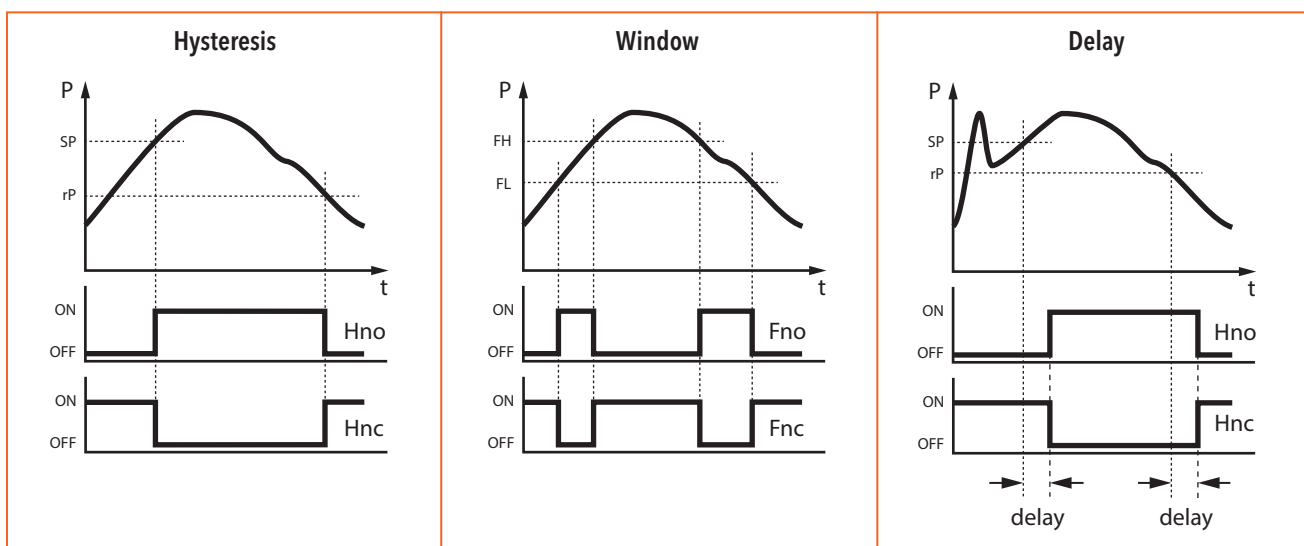

### Additional information

#### Documents

Data sheet	<a href="http://www.trafag.com/H72304">www.trafag.com/H72304</a>
Instructions	<a href="http://www.trafag.com/H73303">www.trafag.com/H73303</a>
Flyer	<a href="http://www.trafag.com/H70682">www.trafag.com/H70682</a>