

# PRESSOSTAT

Swiss based Trafag is a leading international supplier of high quality sensors and monitoring instruments for measurement of pressure and temperature.

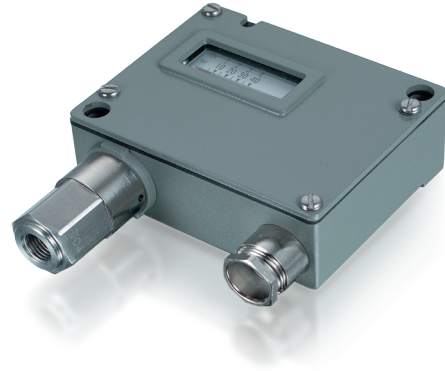

## Applications

- Shipbuilding
- Engine manufacturing
- Railways
- Machine tools
- Hydraulics

## Features

- Rugged aluminium housing
- Protection IP65
- Any mounting position possible





08/2024

Data sheet H72259t

Technical Data			
Measuring principle	Piston	Repeatability	± 1.0 % FS typ.
Measuring range	1 ... 10 to 60 ... 600 bar	Media temperature	O-Ring NBR: -30°C ... +100°C O-Ring FKM: -15°C ... +150°C
Output signal	1 Floating change-over contact (SPDT)	Ambient temperature	-20°C ... +70°C
Switching differential	Not adjustable	Approval / conformity	ABS, BV, CCS, DNV-GL, KRS, LRS, RINA EN60730-1/ EN60730-2-6: Typ 2.B.H

Subject to change

## Ordering information/type code

					XXX	XX	XX	XXX	XX	XX	
<b>Custom build code</b>	With display and adjusting screw				944						
	Without display, with adjusting screw				947						
<b>Microswitch</b>	Small switching differential, standard vibration resistance <sup>1) 2)</sup>									10	
	Average switching differential, standard vibration resistance <sup>1)</sup>									11	
	Average switching differential, increased vibration resistance  <sup>1)</sup>									23	
	Large switching differential, high vibration resistance  <sup>1)</sup>									26	
	With gold plated contacts, standard vibration resistance <sup>1)</sup>									21	
<b>Range</b>	<b>Range [bar]</b>	<b>Over pressure [bar]</b>	<b>Burst pressure [bar]</b>		<b>Range [bar]</b>	<b>Over pressure [bar]</b>	<b>Burst pressure [bar]</b>				
	1 ... 10	100	200	78	16 ... 160	400	600	84			
	4 ... 40	200	400	81	25 ... 250	400	600	85			
	6 ... 60	200	400	82	40 ... 400	800	1000	86			
	10 ... 100	200	400	83	60 ... 600	800	1000	87			
<b>Sensor</b>	<b>Sensor material</b>	<b>Sensor housing material</b>	<b>Thread</b>	<b>Range</b>		<b>Sensor material</b>	<b>Sensor housing material</b>	<b>Thread</b>	<b>Range</b>		
	1.4435, O-Ring NBR	1.4435	G1/4" female	78	700	1.4435, O-Ring NBR	1.4435	G1/2" male	82, 83	710	
	1.4435, O-ring FKM	1.4435	G1/4" female	78	701	1.4435, O-Ring FKM	1.4435	G1/2" male	82, 83	711	
	1.4435, O-ring NBR	1.4435	G1/2" male	78	702	1.4435, O-Ring NBR	1.4435	G1/4" female	84, 85	712	
	1.4435, O-ring FKM	1.4435	G1/2" male	78	703	1.4435, O-Ring FKM	1.4435	G1/4" female	84, 85	713	
	1.4435, O-Ring NBR	1.4435	G1/4" female	81	704	1.4435, O-Ring NBR	1.4435	G1/2" male	84, 85	714	
	1.4435, O-Ring FKM	1.4435	G1/4" female	81	705	1.4435, O-Ring FKM	1.4435	G1/2" male	84, 85	715	
	1.4435, O-Ring NBR	1.4435	G1/2" male	81	706	1.4435, O-Ring NBR	1.4435	G1/4" female	86, 87	722	
	1.4435, O-Ring FKM	1.4435	G1/2" male	81	707	1.4435, O-Ring FKM	1.4435	G1/4" female	86, 87	723	
	1.4435, O-Ring NBR	1.4435	G1/4" female	82, 83	708	1.4435, O-Ring NBR	1.4435	G1/2" male	86, 87	724	
	1.4435, O-Ring FKM	1.4435	G1/4" female	82, 83	709	1.4435, O-Ring FKM	1.4435	G1/2" male	86, 87	725	
	<b>Fixing</b>	Direct on sensor or housing									00
		With mounting bracket									31
	<b>Accessories</b>	Lead seal (manipulation protection)									16
		Screwed cable gland M20x1.5 (EN50262) 									07
		Screwed cable gland M24x1.5 (DIN89280) 									27
		Screwed cable gland M18x1.5 (DIN89280) 									40
		Damping elements and snubber see data sheet H72258									

<sup>1)</sup> Switching differential not adjustable

<sup>2)</sup> Not suitable for applications under vibration

## Standard products (extra short lead time)

Product No.	Type Code	Pressure range [bar]	Over pressure max. [bar]	Switching differential [bar]	Diameter Y [mm]	Length X [mm]
PK10	944 2378 700	1 ... 10	100	0.45 ... 0.9 (fix)	33	47
PK40	944 2381 704	4 ... 40	200	1.8 ... 3.4 (fix)	27	42.5
PK100	944 2383 708	10 ... 100	200	3.2 ... 7.5 (fix)	27	42.5
PK250	944 2385 712	25 ... 250	400	5.2 ... 16 (fix)	27	42.5

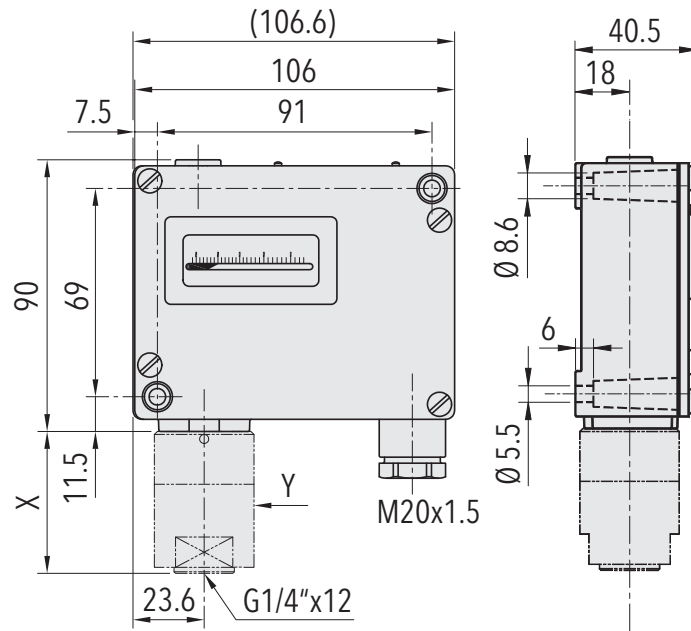

Specifications		
<b>Accuracy</b>	Repeatability	± 1.0 % FS typ.
	Scale accuracy typ.	± 2.0 % FS typ.
	Switching differential	See table
	Adjustment range switchpoint <sup>1)</sup>	10% ... 90% FS
<b>Environmental conditions</b>	Ambient temperature	-20°C ... +70°C
	Media temperature	O-Ring NBR: -30°C ... +100°C O-Ring FKM: -15°C ... +150°C
	Storage temperature	-25°C ... +85°C
	Protection	IP65
	Humidity	Max.95 % relative
	Vibration	Switch 23/26: 5...25 Hz: ±1.6 mm 25...100 Hz: 4g
	Shock	50g/ 11ms
<b>Mechanical Data</b>	Sensor	1.4435
	Housing	AlSi10Mg/ Epoxy coated
	Sealing	NBR/FKM
	Screwed cable gland	Brass nickel plated
	Mounting torque	Max. 25 Nm
	Installation	any position
	Weight	~ 710 g
<b>Microswitch</b>	Rating	See table
	Resistance of insulation	500 VDC / 100 MΩ
	Dielectric strength	U ≤ 250V: 1.45 kV / U ≤ 500V: 2 kV terminal ground
	Life time (mechanical)	Microswitch 10/11: 20 Mio. cycles Microswitch 21: 0.5 Mio. cycles Microswitch 23/26: 0.3 Mio. cycles
<b>Electrical connection</b>	Electrical connections	Terminal screw
	Cable gland	M20x1.5 Cable-Ø 6...13 mm
	Terminal screw	3 x 1.5...4 mm <sup>2</sup>

<sup>1)</sup> Other adjustment ranges upon request

Additional information		
<b>Documents</b>	Data sheet	<a href="http://www.trafag.com/H72259">www.trafag.com/H72259</a>
	Instructions	<a href="http://www.trafag.com/H71261">www.trafag.com/H71261</a>

## Dimensions

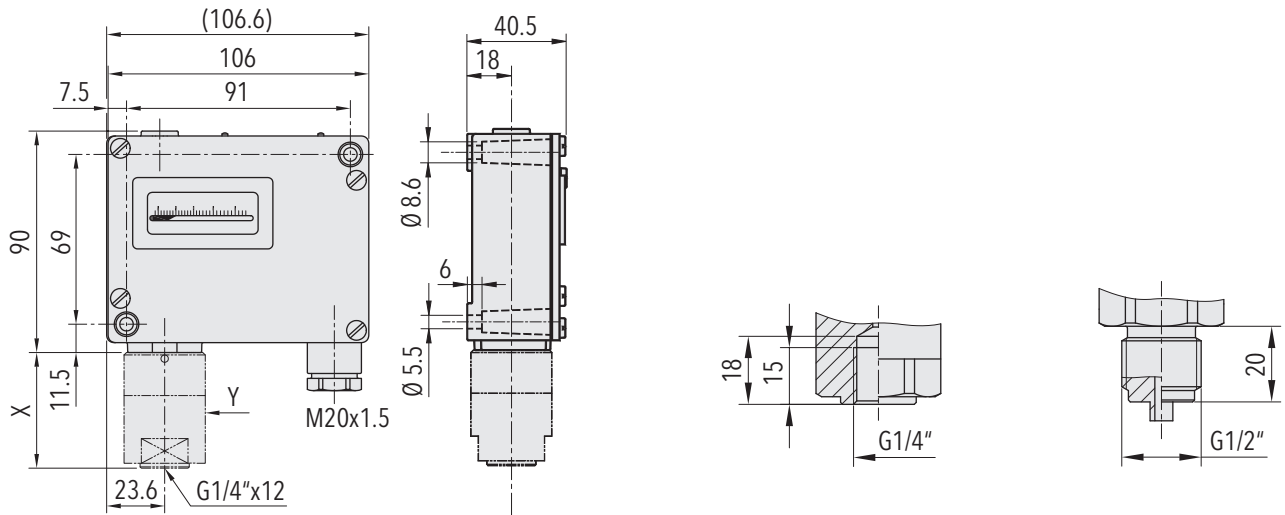

Dimension X and Y see data sheet H72271

G1/4" female

G1/2" male

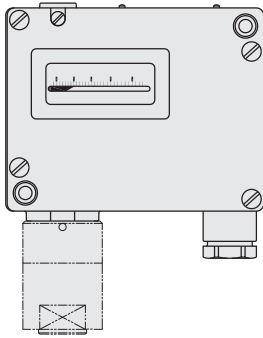

944.XX.XX.XXX.XX.XX

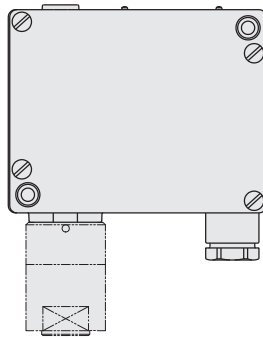

947.XX.XX.XXX.XX.XX

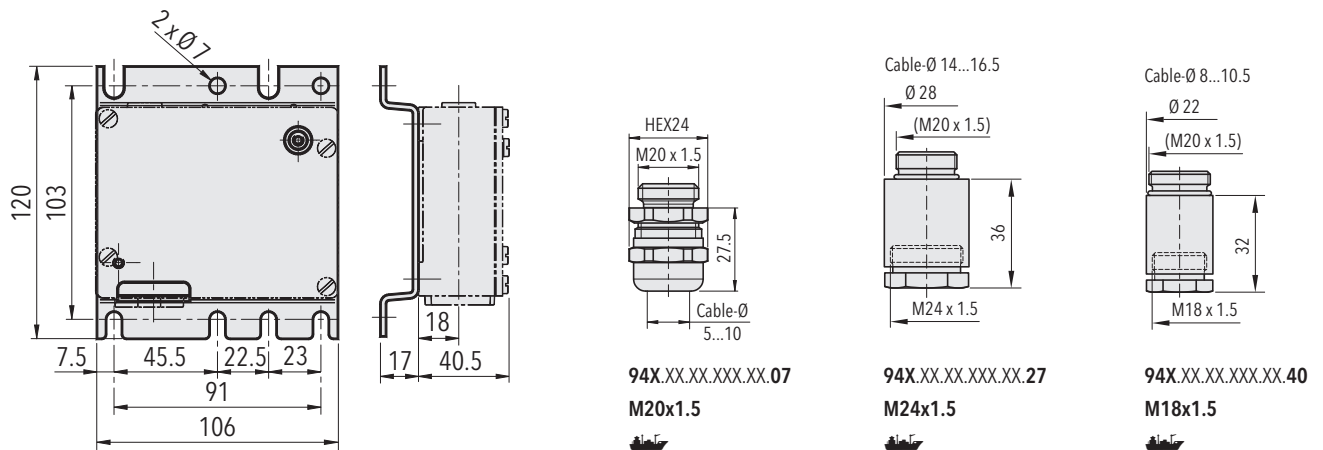

94X.XX.XX.XXX.31.XX

94X.XX.XX.XXX.XX.07  
M20x1.5



94X.XX.XX.XXX.XX.27  
M24x1.5

94X.XX.XX.XXX.XX.40  
M18x1.5

## Switching differential typ. @ 25°C

Measuring range of piston sensor	[bar]	1 ... 10	4 ... 40	6 ... 60	10 ... 100	16 ... 160	25 ... 250	40 ... 400	60 ... 600
<b>Microswitch 10</b> Switching differential (not adjustable, variable according to set point)	[bar]	0.4 ... 0.8	1.5 ... 2.5	2.0 ... 3.7	2.6 ... 5.5	3.4 ... 8.0	4.3 ... 11	5.3 ... 16	6.5 ... 21
<b>Microswitch 11, 21, 23</b> Switching differential (not adjustable, variable according to set point)	[bar]	0.45 ... 0.9	1.8 ... 3.4	2.3 ... 4.8	3.2 ... 7.5	4.1 ... 11	5.2 ... 16	6.5 ... 23	8.0 ... 32
<b>Microswitch 26</b> Switching differential (not adjustable, variable according to set point)	[bar]	0.55 ... 1.1	2.0 ... 4.0	2.7 ... 5.7	3.7 ... 9.0	4.7 ... 13	6.0 ... 19	7.5 ... 28	9.0 ... 38

## Electrical data switch

Type	Features	Rating	
		Resistive Load (Inductive Load)	
		AC	DC
<b>10</b>	Small switching differential (not recommended for applications under vibrations)	125 V, 10 (1.5) A 250 V, 10 (1.25) A	250 V, 0.2 (0.02) A 125 V, 0.4 (0.03) A 30 V, 2 (1) A 14 V, 15 (2.5) A
<b>11</b>	Average switching differential, standard vibration resistance	125 V, 15 (1.5) A 250 V, 15 (1.25) A 500 V, 10 (0.75) A	250 V, 0.25 (0.03) A 125 V, 0.5 (0.05) A 30 V, 6 (1.5) A 14 V, 15 (1.5) A
<b>23</b> 	Average switching differential, increased vibration resistance	125 V, 15 (1.5) A 250 V, 15 (1.25) A 500 V, 10 (0.75) A	250 V, 0.3 (0.05) A 125 V, 0.6 (0.1) A 30 V, 15 (1.5) A 14 V, 15 (1.5) A
<b>26</b> 	Large switching differential, high vibration resistance	125 V, 15 (1.5) A 250 V, 15 (1.25) A 500 V, 10 (0.75) A	250 V, 0.3 (0.2) A 125 V, 0.75 (0.4) A 30 V, 15 (1.5) A 14 V, 15 (1.5) A
<b>21</b>	With gold plated contacts, standard vibration resistance	24 V, 0.1 (0.1) A 12 V, 1 (1.0) A 5 V, 2 (2.0) A	24 V, 0.1 (0.1) A 12 V, 1 (1.0) A 5 V, 2 (2.0) A

## Electrical Connection

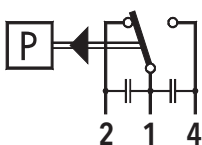

Switch 11/12/23

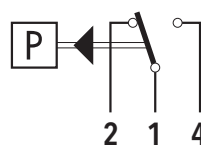

Switch 26