

FROSTSTAT

Swiss based Trafag is a leading international supplier of high quality sensors and monitoring instruments for measurement of pressure and temperature. The Froststat was specifically designed as single stage temperature controller for monitoring temperature around 0°C, i. e. to prevent ice build-up on air heaters.

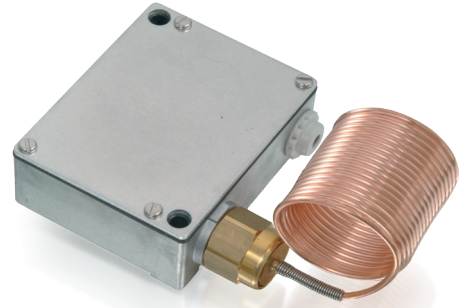

Applications

- HVAC
- Refrigeration

Features

- Rugged aluminium housing
- Short response time
- Protection IP54
- Electrical connection on terminal screw

Technical Data

Designation of application	Frost protection thermostat	Switching differential	Not adjustable
Measuring range	-5°C ... +15°C	Repeatability	± 0.5 % FS typ.
Output signal	Floating change-over contact	Approval / conformity	EN60730-1/ EN60730-2-9: Typ 2.B.H

08/2024

Data sheet H72123h

Subject to change

Ordering information/type code

		XXX . XXXX	XXXXXX
Custom build code	Sensor 3m	990 . 1299	
	Sensor 6m	991 . 1299	
	Sensor 3m, limiter	992 . 1299	
	Sensor 6m, limiter	993 . 1299	
Accessories	6 pcs. Capillary holder		K80140

Standard products (extra short lead time)

Product No.	Type Code	Sensor material	Set point adjustment
F15	991 1299 000	Copper capillary tube, L=6m	Internal setpoint adjustment
F153	990 1299	Copper capillary tube, L=3m	Internal setpoint adjustment
F15R	993 1299 000	Copper capillary tube, L=6m	Internal setpoint adjustment and external reset knob
F153R	992 1299	Copper capillary tube, L=3m	Internal setpoint adjustment and external reset knob

Specifications		
Accuracy	Repeatability	± 0.5 % FS typ.
	Scale accuracy typ.	± 1.5 % FS typ.
	Switching differential	2.0°C typ.
Environmental conditions	Media temperature	Sensor temperature max.: 140°C Sensor response length : ~ 30 cm
	Ambient temperature	Max. operating temperature: +70°C Min. operating temperature: switch point + 2°C
	Storage temperature	-30°C ... +70°C
	Protection	IP 54
	Humidity	Max. 95 % relative
Mechanical Data	Sensor housing	Copper (Cu)
	Filling	Freon R 134, gaseous
	Housing	AlSi9Pb3
	Screwed cable gland	Polyethylen (PE)
	Installation	any position
	Weight	~ 850 g
Microswitch	Rating	See table below
	Resistance of insulation	> 2 MΩ
	Dielectric strength	2 kV terminal ground
	Life time (mechanical)	0.3 Mio. cycles
Electrical connection	Cable gland	M20x1.5 Cable-Ø 8...13 mm
	Terminal screw	3 x 1 ... 2.5 mm ²

Electrical data switch			
Type	Features	Rating	
		Resistive Load (Inductive Load)	
		AC	DC
12	Average switching differential, high vibration resistance	125 V, 15 (1.5) A 250 V, 15 (1.25) A 500 V, 10 (0.75) A	250 V, 0.3(0.2) A 125 V, 0.75(0.4) A 30 V, 15(1.5) A 14 V, 15 (1.5) A

Electrical Connection

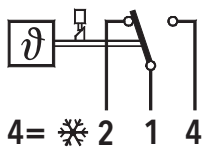

992/993
Limiter, decreasing

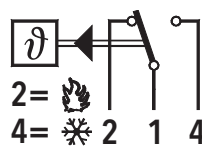

990/991

Dimensions

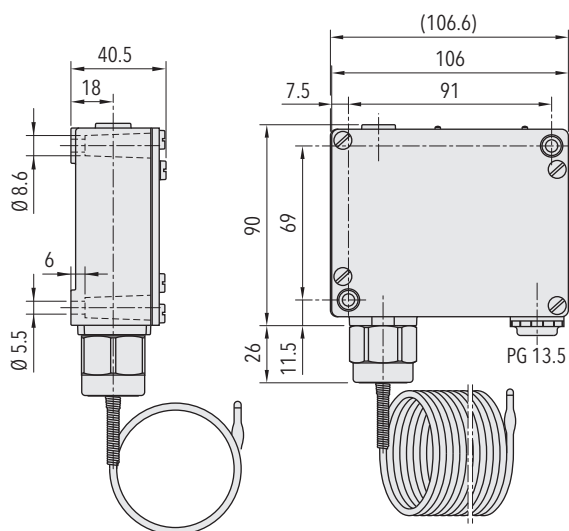

990/991.XXXX.XX

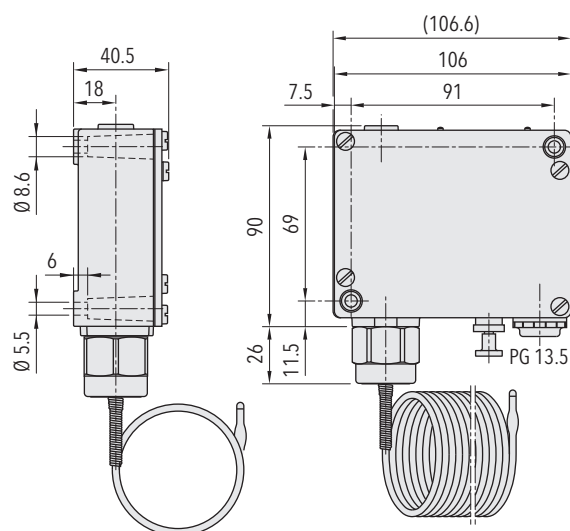

992/993.XXXX.XX

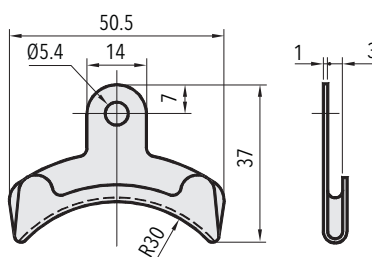

99X.XXXX.K80140

Additional information

Documents

Data sheet

www.trafag.com/H72123

Instructions

www.trafag.com/H70821